

Xena Console

assembly guide

introduction



Valued Customer,

We design and carefully manufacture our products for our customers, We wish that our customers to have fun while they are doing their new furniture

The product you just purchased was subjected to all sorts of tests and controls before sending out to you.

Hope you enjoy your new furniture!!!



Before starting, please check all components and accessories according to the provided list. If you purchased more than one product, to prevent confusion, be sure that you completed the first product, then start the next one. Please make sure that you select correct numbered part and use specific connector to assemble. We do not recommend any modification or rotation in assembly. Please follow the manual carefully.



Furniture parts are going to several manufacturing procedures. During this process, parts can have little dust or marks. Please clean the parts with dump cloth before assembly to get the best result. Usual cleaning would be suffice.



Although all products are carefully manufactured and packed, sometimes we experience damage during transportation. In such cases, please check the damaged part, note the part number written on the part and do not hesitate to contact us



Do not use your furniture for out of purposes. If you would like to use it out of purpose or would like to do some modification or rotation, please contact us for more details.

Please do not expose your furniture with excessive heat, cold and humidity because product can be affected negatively.

before you start

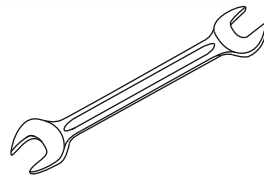
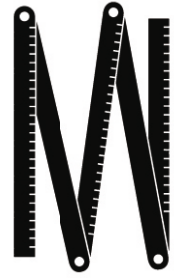
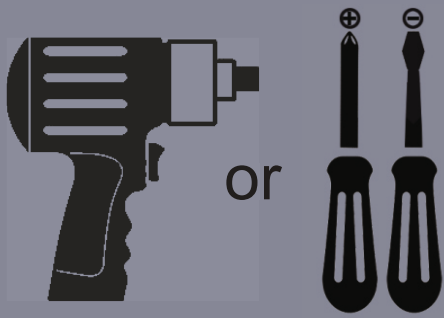

Get required installation tools prepared.

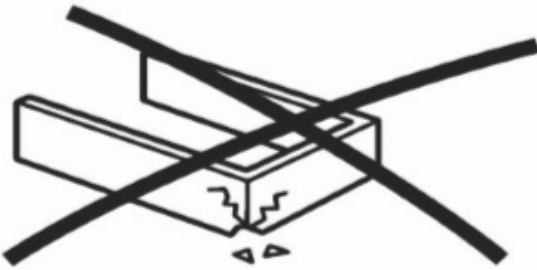

Do not install the product on rough surfaces.

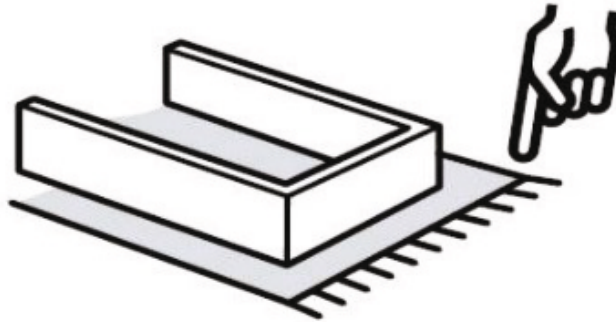

Get help from someone else!

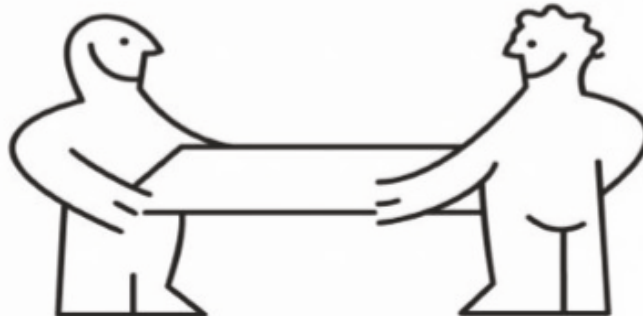

Part1	3x
Part2	2x
Part3	6x
TOTAL	11x

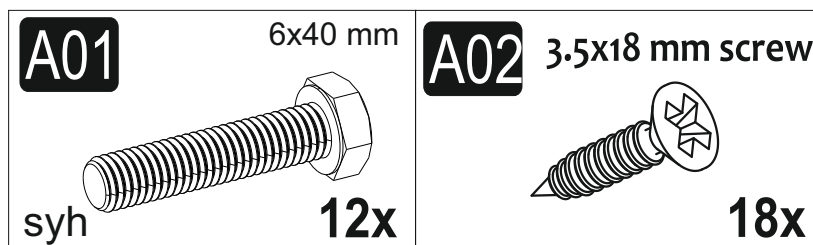
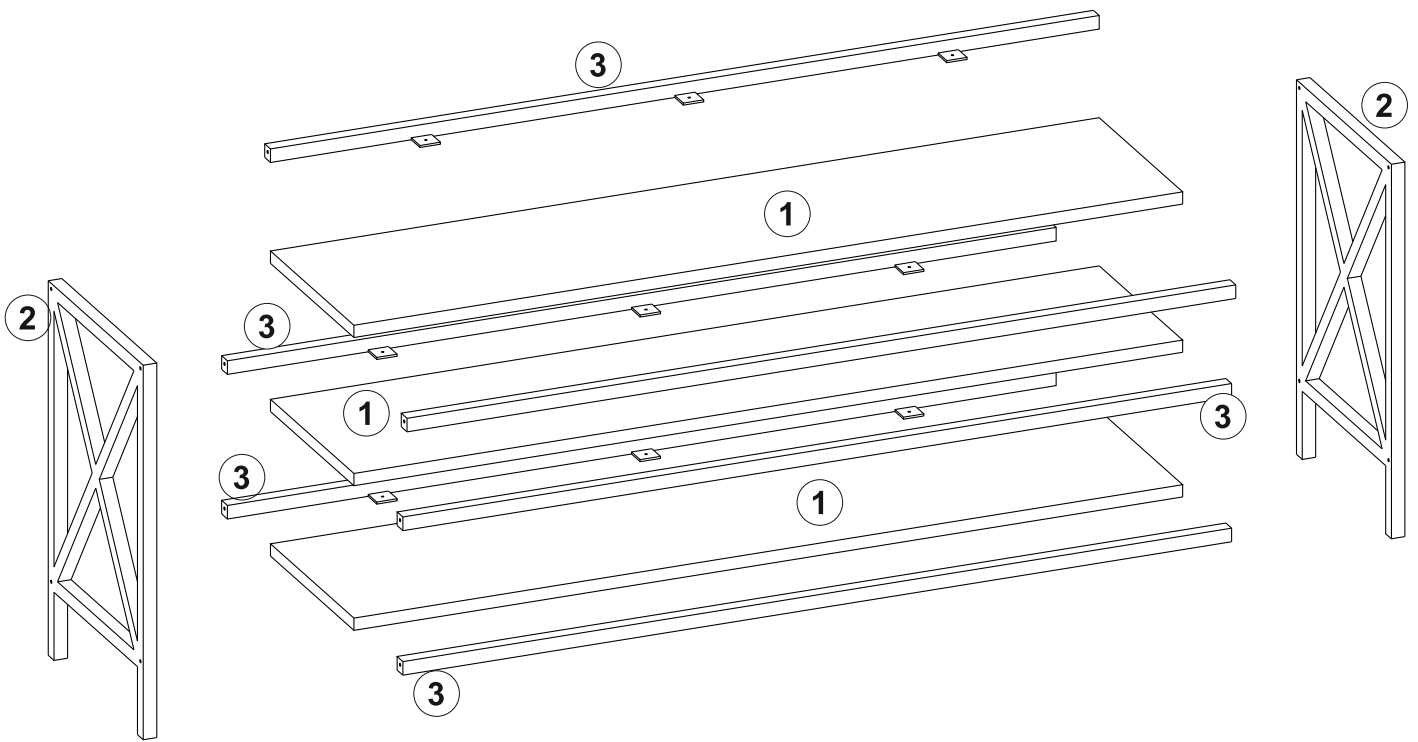

1 step a

*Please attach the pieces #3 to the piece #2 as shown below

*Now turn the A01 (bolt) clockwise direction with help of a spanner until it becomes tight

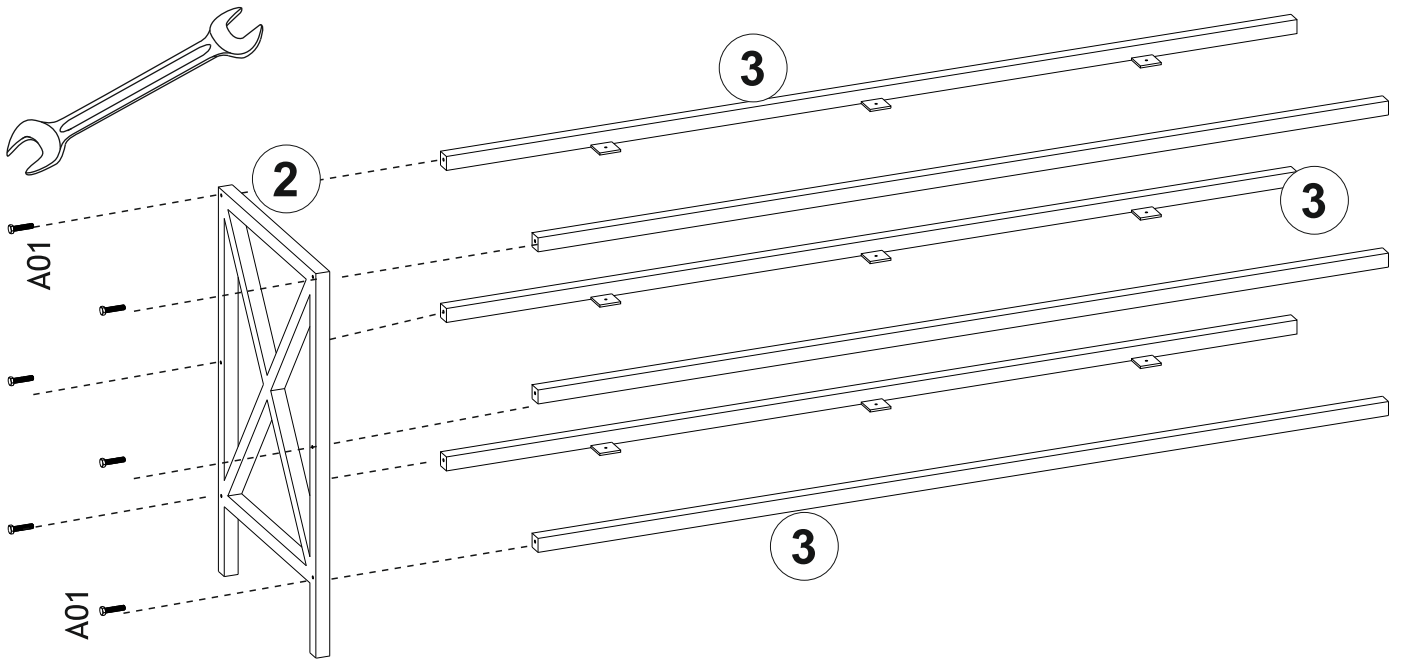

2 step b

*Please attach the pieces #3 to the piece #2 as shown below

*Now turn the A01 (bolt) clockwise direction with help of a spanner and leave it loose

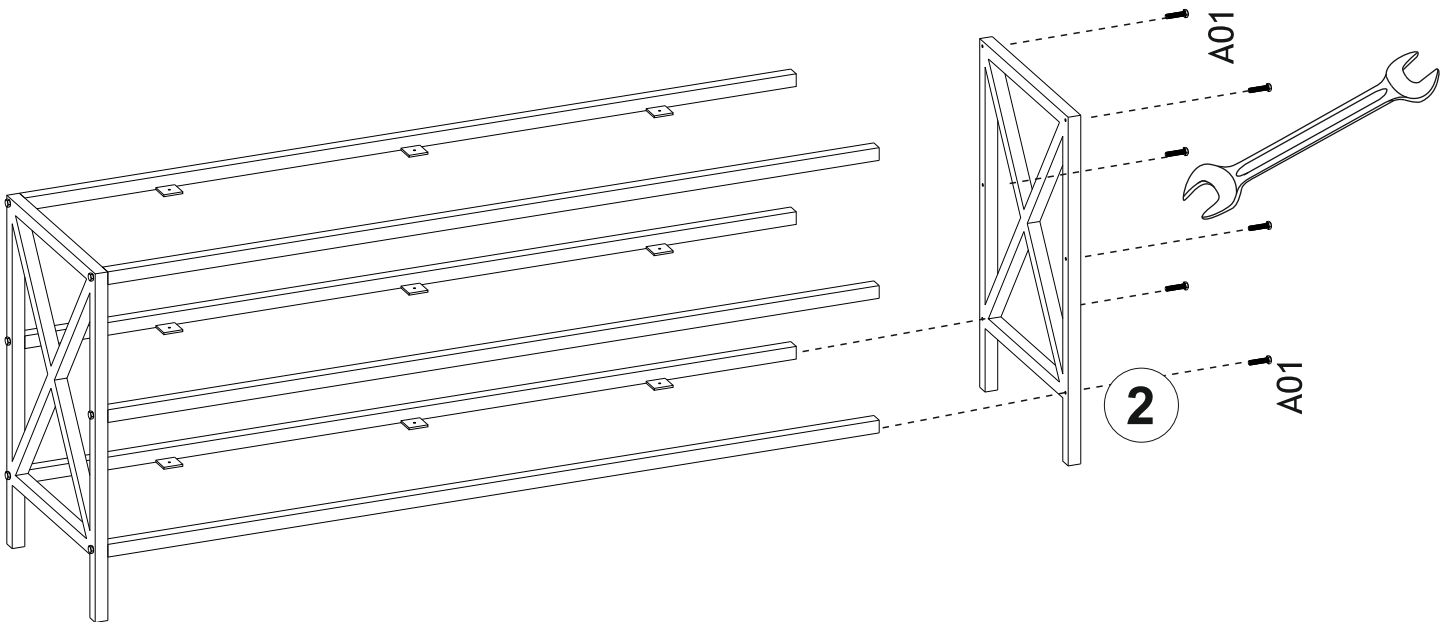

Please do not turn the A01(bolt) until it becomes tight so that you can put the part 1# easily

3 step c

*Please put the pieces #1 onto metal brackets as shown below

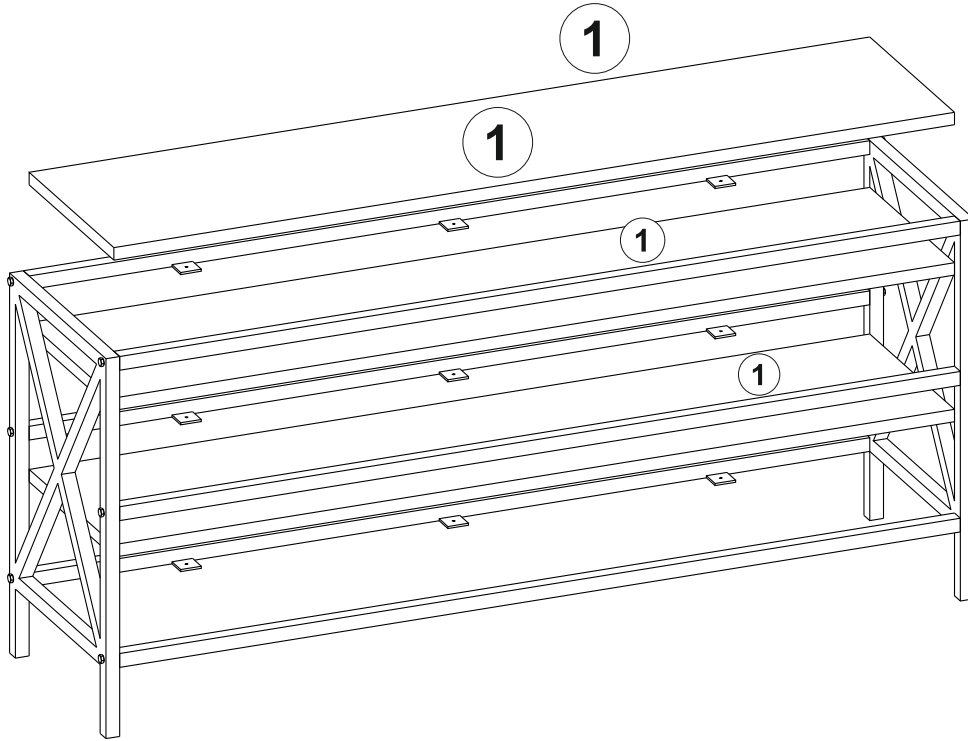

4 step d

*Please turn the **A01(bolt)** we left loose in previous step with help of a spanner.

*Please screw the **A02(3.5x18 mm screw)** with the help of screwdriver or electric drill.

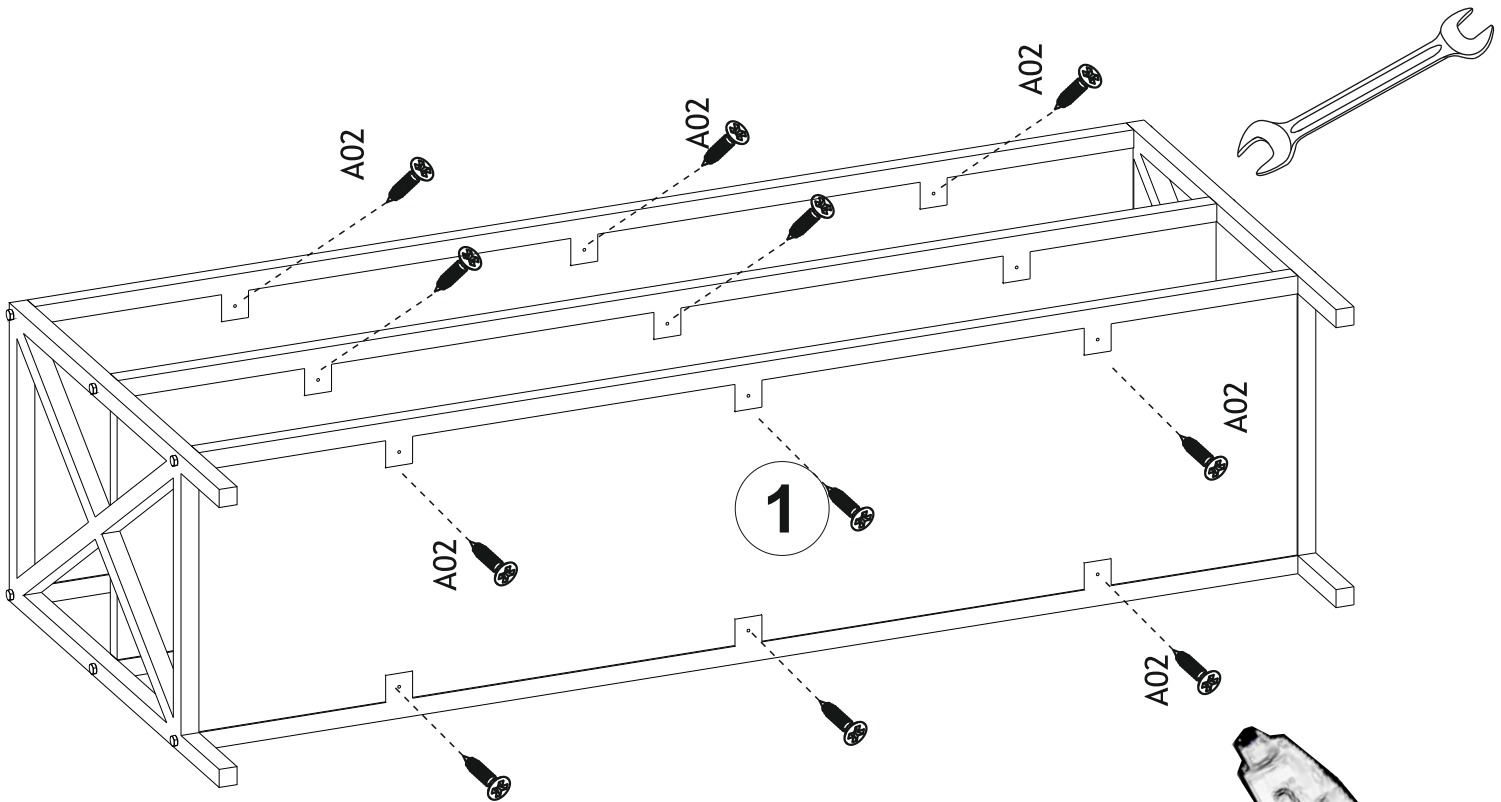

 Please do not neglect screwing all A02 otherwise, pieces #1 may fall down if pressure applied

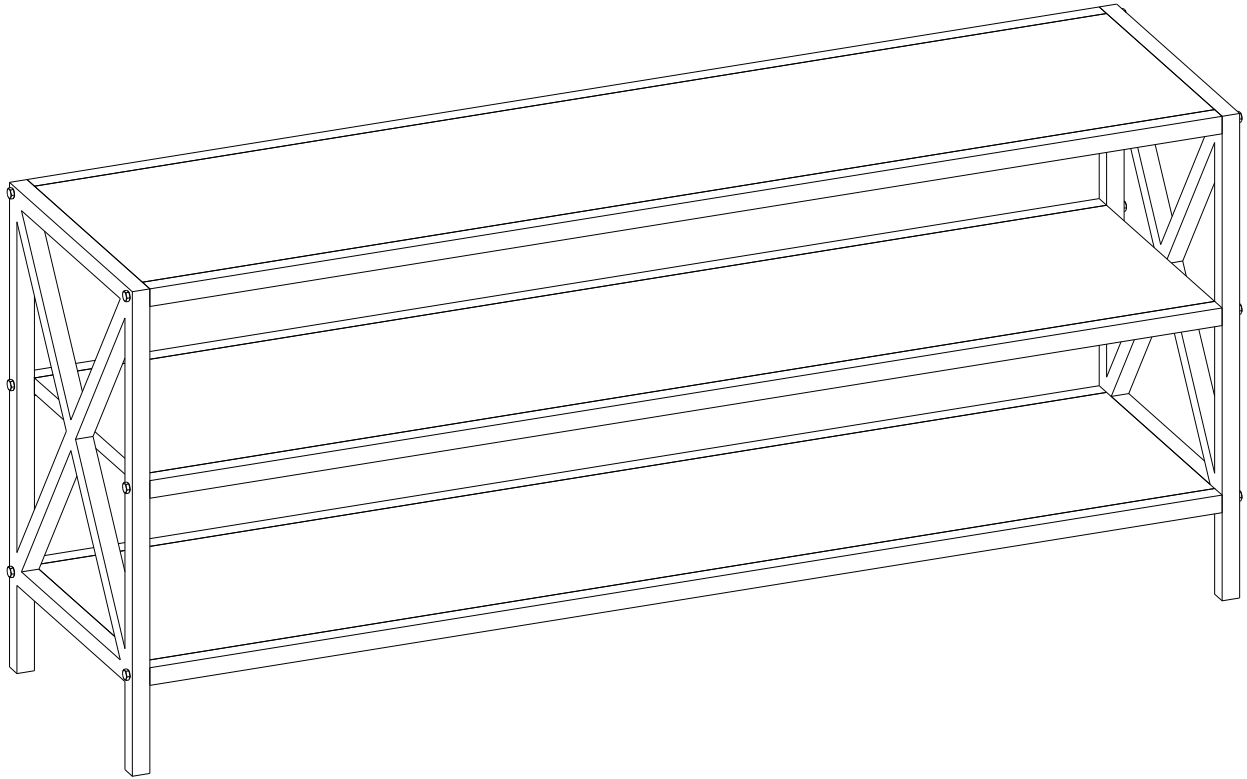

Enjoy your Decorotika product!